

### Features

- All valve materials comply with FDA and USDA requirements
- Tri-Clamp ends for hygienic connections
- Dyneon® TF-1641 (PTFE) FDA approved ball seats and cavity fillers
- Triple PTFE/Viton® high cycle live loaded stem seal packing
- Highly polished internals and end caps with 8-12 Ra finish
- Spring Return or Double Acting Actuators
- Type IP66 & IP68 weatherproof actuator
- Rugged scotch yoke construction tested for 1 million+ cycles
- Anodized aluminum body with epoxy-polyester end covers
- Namur and ISO mounting standards
- Highly visible valve position indicator
- Actuator factory lubricated for normal lifetime

### Applications

Sanitary ball valves are typically used for food, beverage, pharmaceutical, personal care, and pet care applications where sanitary construction is required, as well as for utility and process applications where quick clamp connections are beneficial. Suitable for vacuum service to 29"Hg.

### Operation

Double acting scotch yoke actuators use air pressure to open and air pressure to close the ball valve (4-way pilot). Spring return scotch yoke actuators use air pressure to open and springs to close the ball valve (3-way pilot). Actuator will work with filtered dry or lubricated compressed air. Recommended air supply pilot pressure should be between 58 and 87 PSI. Easy to read visual valve position indicator located on top of actuator.

### Construction

<b>Valve Body</b>	ASTM 316 Stainless Steel
<b>Ball/Stem</b>	ASTM 316 stainless steel
<b>Ball Seats/ Cavity Filler</b>	Dyneon® PTFE
<b>Stem Seals</b>	PTFE/ Viton®
<b>Actuator Seals</b>	NBR
<b>Actuator Body/ End Covers</b>	Hard anodized aluminium/ Polyester coated aluminium
<b>Position Indicator</b>	Glass filled Polyamide
<b>Fasteners</b>	ASTM 304 Stainless Steel



### Description

Heavy duty quarter turn scotch yoke actuators designed for long life and tested for a minimum 1 million+ operations. Investment cast 3-piece full port stainless steel body and end caps for unrestricted flow and minimum pressure loss. Valve seals are cavity filled Dyneon® PTFE. Self adjusting live loaded stem seal packing helps compensate for wear, pressure or temperature fluctuations, extending the cycle life of the valve. Blow-out proof stem. Cavity fillers avoid media entrapment and quick clamp end connections allow for easy cleaning. Standard Namur mounting pads for optional accessory confirmation switches and pilot valves.

### Approvals– Actuators

- CE Declaration of conformity
- EN ISO 12100:2010
- EN ISO 4414:2010
- ISO5211/ DIN3337 valve mounting
- Namur VDI/VDE 3845 accessory mounting
- SIL3– EN 17955:2024 & IEC 61508-1/-2:2010

### Standards– Valves

- CE conformity– PED 2014-68/UE
- Construction:
  - ANSI B16/B2/B18
  - FDA 21 CFR 177.1550
  - ANSI B16.34
- Pressure Testing:
  - API 598
- Marking:
  - MSS-SP-25

## Features

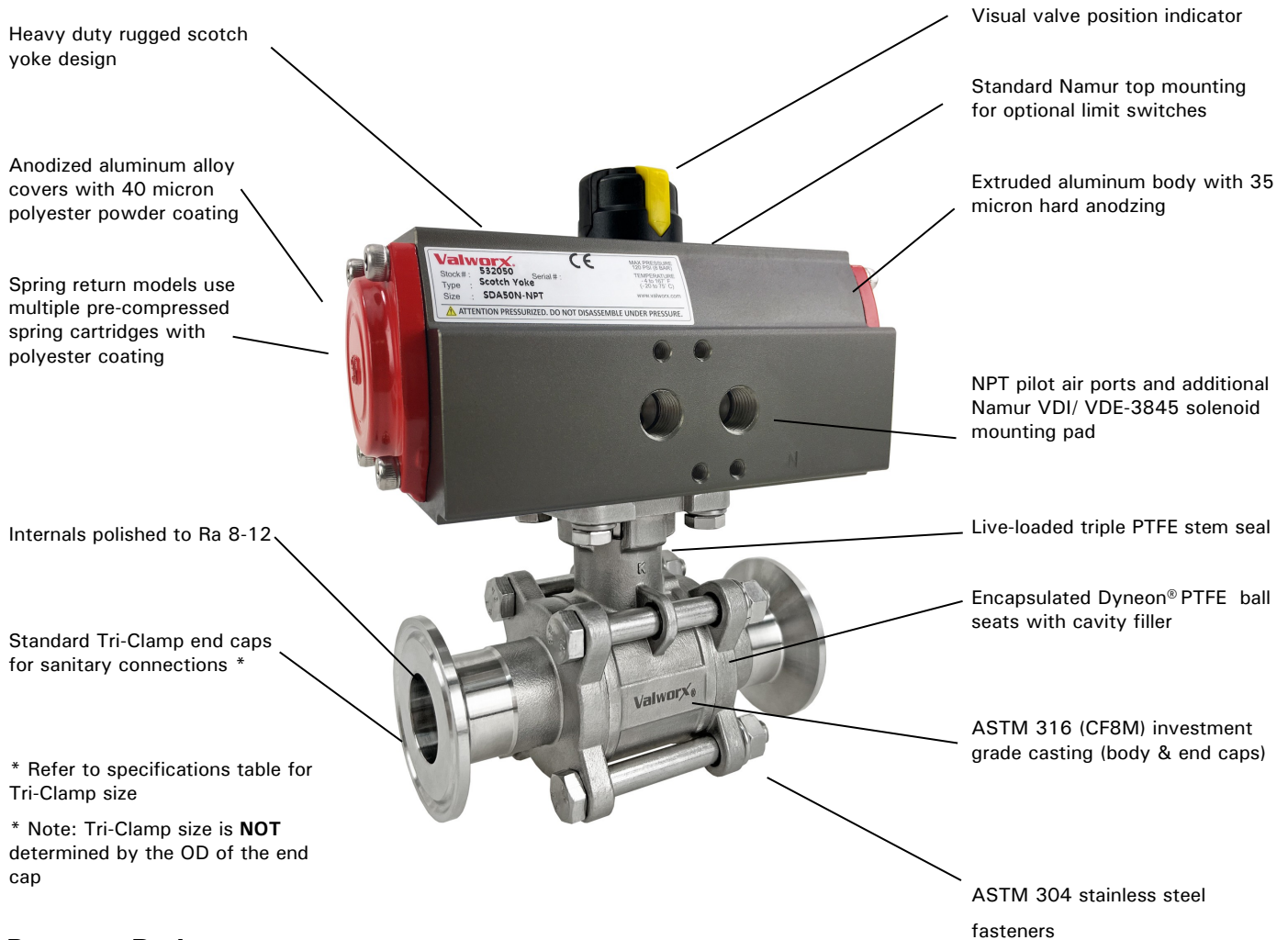

## Pressure Rating

**Shell Pressure Rating (Max)\*:** 1000 PSI @ 120°F (1/2" to 2"),  
800 PSI (2 1/2" to 4") Suitable for vacuum service to 29"Hg.

**Recommended Air Pilot Pressure:** 58-87 PSI (4-6 Bar)

**Max Air Pilot Pressure:** 120 PSI

## Temperature Rating

**Temperature Rating:** -4° to 356° F (-20 to 180°C)

\*See P/T Chart

**Actuator Temperature Rating:** -4 to 167° F (-20 to 75° C)

\*See P/T chart

## Optional Accessories

- DMS: Direct Mount Solenoid
- pilot to electrically operate the ball valve
- VPS: Valve Position Switches
- limit switches to confirm valve position
- HTB: High Temperature Bracket
- increases media working temperature
- DSP: Digital Smart Positioner
- simplify throttling applications

## Specifications (English units)

Stock Number	Pipe Size (inch)	Tri-Clamp Size (inch)	Cv Flow Factor	Shell Pressure Max.(PSI)*	Cycle Time /90° (seconds)	Pilot Air Port (NPT)	Air Volume (standard cubic inches)
<b>VALVE WITH SPRING RETURN ACTUATOR</b>							
571300A	1/2	3/4	13.0	1000	0.3-0.5	1/4	73.2
571301A	3/4	3/4	18.0	1000	0.3-0.5	1/4	73.2
571302A	1	1-1/2	48.0	1000	0.3-0.5	1/4	73.2
571303A	1-1/2	1-1/2	165.0	1000	0.4-0.6	1/4	109.8
571304A	2	2	207.0	1000	0.4-0.6	1/4	109.8
571305A	2-1/2	2-1/2	450.0	800	0.7-1.2	1/4	512.6
571306A	3	3	780.0	800	5.0-6.0	1/4	1067.9
571307A	4	4	1050.0	800	5.0-6.0	1/4	1067.9
<b>VALVE WITH DOUBLE ACTING ACTUATOR</b>							
571200A	1/2	3/4	13.0	1000	0.3	1/4	146.5
571201A	3/4	3/4	18.0	1000	0.3	1/4	146.5
571202A	1	1-1/2	48.0	1000	0.3	1/4	146.5
571203A	1-1/2	1-1/2	165.0	1000	0.4	1/4	219.7
571204A	2	2	207.0	1000	0.4	1/4	219.7
571205A	2-1/2	2-1/2	450.0	800	0.6	1/4	402.8
571206A	3	3	780.0	800	0.6	1/4	402.8
571207A	4	4	1050.0	800	0.8	1/4	842.1

Cv = The GPM of water at 60° F that will pass through the valve with 1 PSI pressure drop

\* Pressure @ -4° to 356° F (reduced pressure at higher temperatures—see P/T chart)

• Torque at 1000 PSI and 72°F

## Pressure/Temperature Chart (PSI/°F)

Standard Units

Temp °F	-4	120	356
Pressure	1000	1000	0

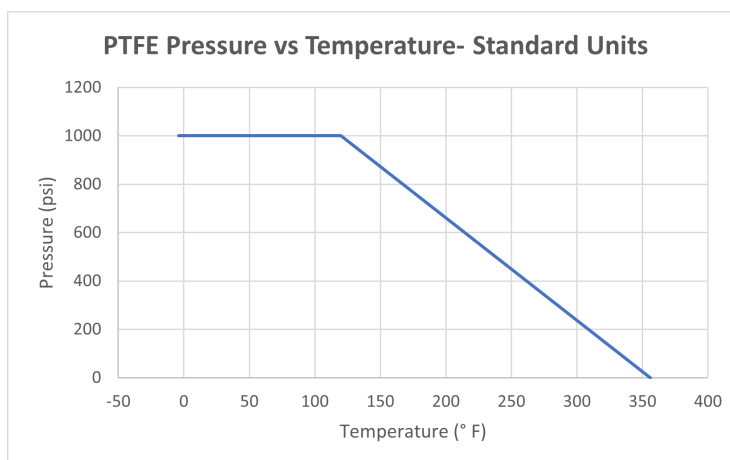

## Specifications (Metric units)

Stock Number	Pipe Size (mm)	Tri-Clamp Size (inch)	Kv Flow Factor	Shell Pressure Max.(Bar)*	Cycle Time/90° (seconds)	Pilot Air Port (NPT)	Air Volume (standard liters)
<b>VALVE WITH SPRING RETURN ACTUATOR</b>							
571300A	12.7	3/4	11.2	69	0.3-0.5	1/4	1.2
571301A	19.1	3/4	15.6	69	0.3-0.5	1/4	1.2
571302A	25.4	1-1/2	41.5	69	0.3-0.5	1/4	1.2
571303A	38.1	1-1/2	142.7	69	0.4-0.6	1/4	1.8
571304A	50.8	2	179.1	69	0.4-0.6	1/4	1.8
571305A	63.5	2-1/2	389.3	55	0.7-1.2	1/4	8.4
571306A	76.2	3	674.7	55	5.0-6.0	1/4	17.5
571307A	101.6	4	908.3	55	5.0-6.0	1/4	17.5
<b>VALVE WITH DOUBLE ACTING ACTUATOR</b>							
571200A	12.7	3/4	11.2	69	0.3	1/4	2.4
571201A	19.1	3/4	15.6	69	0.3	1/4	2.4
571202A	25.4	1-1/2	41.5	69	0.3	1/4	2.4
571203A	38.1	1-1/2	142.7	69	0.4	1/4	3.6
571204A	50.8	2	179.1	69	0.4	1/4	3.6
571205A	63.5	2-1/2	389.3	55	0.6	1/4	6.6
571206A	76.2	3	674.7	55	0.6	1/4	6.6
571207A	101.6	4	908.3	55	0.8	1/4	13.8

\* Pressure range @ -20° to 180° C (reduced pressure for higher temperatures – see P/T chart)

## Pressure/Temperature Chart (Bar/°C)

Metric Units

Temp °C	-20	49	180
Pressure	69	69	0

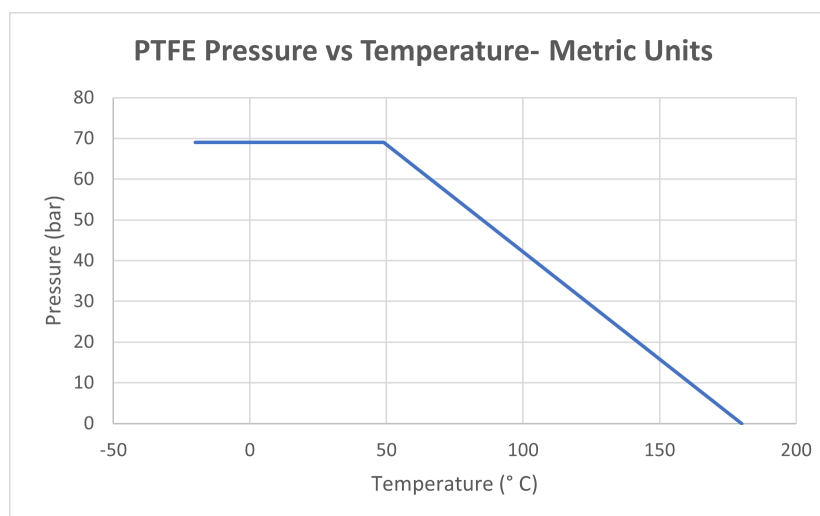

## Dimensions: Spring Return

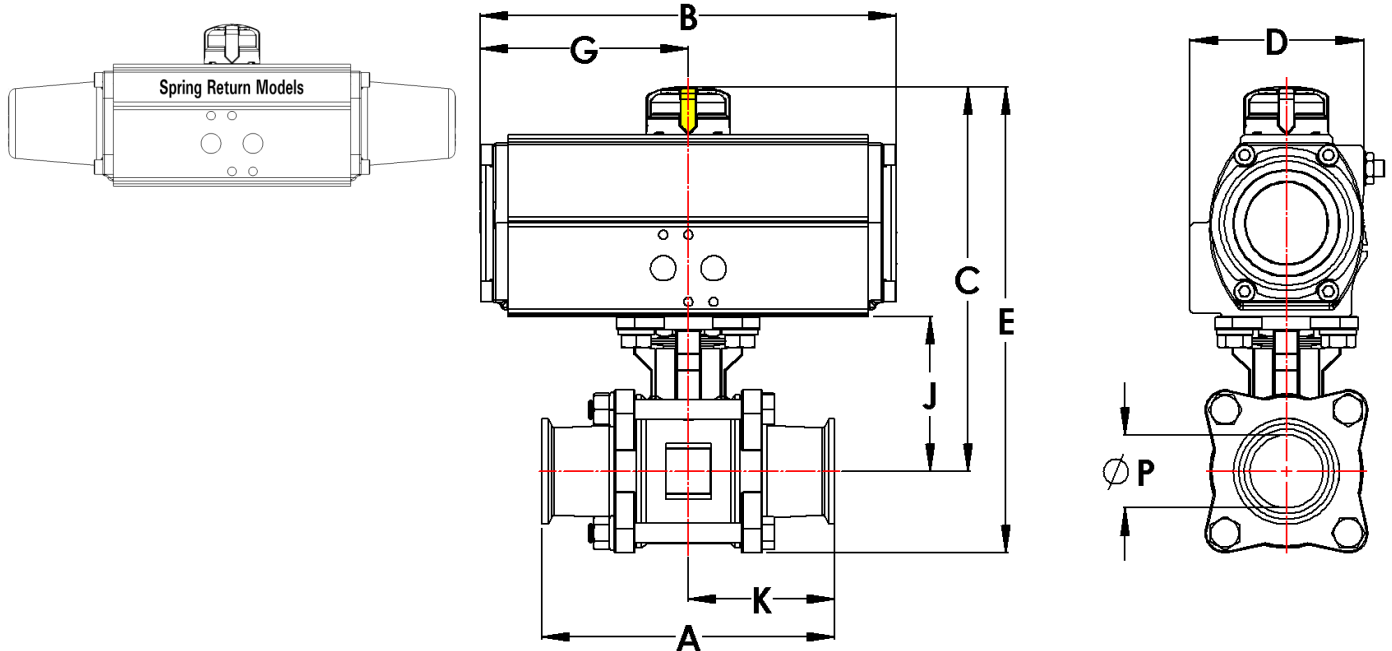

Pipe Size		A	B	C	D	E	G	J	K	P	A & B Ports (NPT)	Weight
1/2	inch	3.5	10.1	4.9	2.9	5.8	5.1	1.5	1.8	0.4	1/4	4.5 lb
	mm	88.9	256.5	124.5	73.7	147.3	129.5	37.0	44.5	10.2	-	2.2 kg
3/4	inch	4.0	10.1	5.2	2.9	6.2	5.1	1.8	2.0	0.6	1/4	5.1 lb
	mm	101.6	256.5	132.1	73.7	157.5	129.5	45.0	50.5	15.2	-	2.3 kg
1	inch	4.5	10.1	5.5	2.9	6.6	5.1	2.1	2.2	0.9	1/4	5.9 lb
	mm	114.3	256.5	139.7	73.7	167.6	129.5	53.5	57.0	22.9	-	2.7 kg
1-1/2	inch	5.5	12.3	15.9	3.5	17.4	6.2	2.9	2.8	1.4	1/4	11.4 lb
	mm	139.7	312.4	403.9	88.9	442.0	157.5	74.8	70.0	35.6	-	5.2 kg
2	inch	6.2	12.3	16.3	3.5	18.1	6.2	3.3	3.1	1.9	1/4	14.4 lb
	mm	157.5	312.4	414.0	88.9	459.7	157.5	83.5	78.0	48.3	-	6.5 kg
2-1/2	inch	7.0	19.6	24.6	5.0	26.8	9.8	4.3	3.9	2.4	1/4	36.1 lb
	mm	177.8	497.8	624.8	127.0	680.7	248.9	108.8	98.5	61.0	-	16.4 kg
3	inch	9.0	23.8	29.2	5.9	31.8	11.9	4.7	4.5	2.9	1/4	62.1 lb
	mm	228.6	604.5	741.7	149.9	807.7	302.3	118.3	114.5	73.7	-	28.2 kg
4	inch	9.5	23.8	30.6	5.9	34.5	11.9	6.1	4.8	3.8	1/4	84.7 lb
	mm	241.3	604.5	77.2	149.9	876.3	302.3	153.8	121.5	96.5	-	38.4 kg

## Dimensions: Double Acting

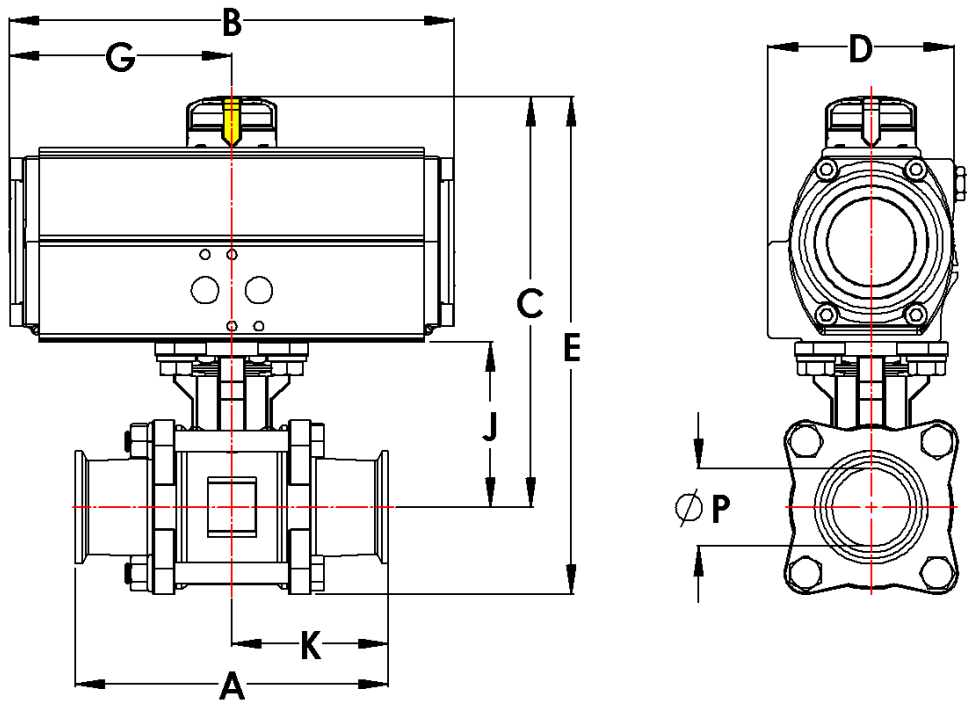

Pipe Size		A	B	C	D	E	G	J	K	P	A & B Ports (NPT)	Weight
1/2	inch	3.5	6.3	4.9	2.9	5.8	3.2	1.5	1.8	0.4	1/4	4.1 lb
	mm	88.9	160.0	124.5	73.7	147.3	81.3	37.0	44.5	10.2	-	1.9 kg
3/4	inch	4.0	6.3	5.2	2.9	6.2	3.2	1.8	2.0	0.6	1/4	4.4 lb
	mm	101.6	160.0	132.1	73.7	157.5	81.3	45.0	50.5	15.2	-	2.0 kg
1	inch	4.5	6.3	5.5	2.9	6.6	3.2	2.1	2.2	0.9	1/4	5.2 lb
	mm	114.3	160.0	139.7	73.7	167.6	81.3	53.5	57.0	22.9	-	2.4 kg
1-1/2	inch	5.5	7.9	7.0	3.5	8.5	4.0	2.9	2.8	1.4	1/4	10.0 lb
	mm	139.7	200.1	177.8	88.9	215.9	101.6	74.8	70.0	35.6	-	4.5 kg
2	inch	6.2	7.9	7.4	3.5	9.2	4.0	3.3	3.1	1.9	1/4	13.0 lb
	mm	157.5	200.1	188.0	88.9	233.7	101.6	83.5	78.0	48.3	-	5.9 kg
2-1/2	inch	7.0	9.9	9.1	3.9	11.3	5.0	4.3	3.9	2.4	1/4	24.4 lb
	mm	177.8	251.5	231.1	99.1	287.0	127.0	108.8	98.5	61.0	-	11.1 kg
3	inch	9.0	9.9	9.5	3.9	12.1	5.0	4.7	4.5	2.9	1/4	32.8 lb
	mm	228.6	251.5	241.3	99.1	307.3	127.0	118.3	114.5	73.7	-	14.9 kg
4	inch	9.5	12.2	11.8	5.0	15.7	6.1	6.1	4.8	3.8	1/4	62.0 lb
	mm	241.3	309.9	299.7	127.0	398.8	154.9	153.8	121.5	96.5	-	28.1 kg