

## Features

- 316SS 3-piece investment cast body
- Pneumatic actuator with integral manual override
- RTFE (reinforced Teflon) ball seats
- Triple PTFE/Viton live loaded stem seals, adjustable
- Valves tested accordance with API 598
- Rack and pinion quarter turn (90°) rotation
- Spring Return or Double Acting Actuators
- Type IP67 weatherproof actuator
- Variable open/close stroke setting
- ATEX approved
- Highly visible valve position indicator
- Actuator factory lubricated for normal lifetime

## Applications

Pneumatic/manual actuated stainless ball valves for control of water, air, oil and other media compatible with the materials of construction. The de-clutch option can be used for manual operation or to set a stop limit for opening or closing. Cycle times approx. 1 to 4 seconds per 90° rotation. Steam service up to 25 PSI with optional high temperature mounting bracket. Suitable for vacuum service to 29.92 InHg (2.3 x 10<sup>-3</sup> Torr).

## Operation

Double acting actuators require air pressure to open and air pressure to close. Spring return actuators require air pressure to open and utilize springs to close for failsafe operation. Pulling the handwheel détente pin allows manual operation of the valve via the handwheel. Re-engaging the détente pin mid-stroke creates a partial stroke position, ie the automatic stroke begins/ends at the locked handwheel position. Rotating the handwheel counterclockwise rotates the output drive counterclockwise when viewed from the top.

Pilot Air should be filtered, dry or lubricated.

## Construction

<b>Valve Body</b>	316 stainless steel ASTM A351 CF8M
<b>Ball/Stem</b>	316 stainless steel
<b>Ball Seats</b>	RTFE (reinforced Teflon)
<b>Stem Seals</b>	PTFE, Viton
<b>Actuator Seals</b>	NBR (Buna-N)
<b>Actuator Body</b>	Extruded aluminium- 35 micron anodizing, 40 micron polyester coated end covers
<b>Position Indicator</b>	Glass filled Polyamide
<b>Fasteners</b>	Stainless Steel

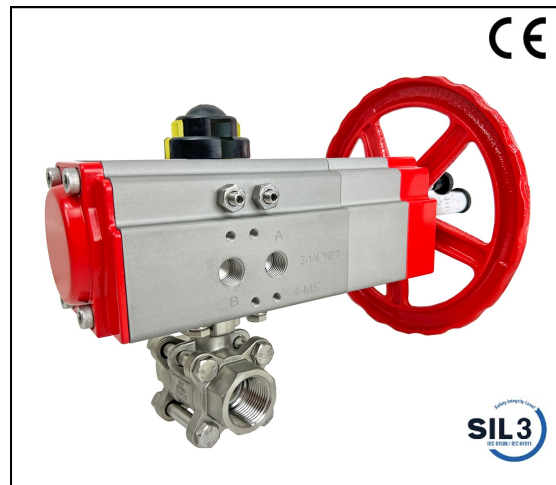

## Description

Valworx heavy duty pneumatic/manual combination actuator features hard anodized aluminum enclosure, type IP67. Actuators are available in double acting and spring return models. Unique 3-piece investment cast bolted body design offers the advantage of a swing-out body for easy inline maintenance. Adjustable live loaded stem seal packing helps compensate for wear, pressure or temperature fluctuations, extending the cycle life of the valve. Blow-out proof stem. Standard Namur mounting pads for optional accessory confirmation switches, pilot valves and valve positioners. Rotation adjustment +5° at the 0° and 90° positions. The integral handwheel is used for manual operation

## Approvals- Actuators

- CE Declaration of conformity
- EN ISO 12100:2010
- EN ISO 4414:2010
- ISO5211/ DIN3337 valve mounting
- Namur VDI/VDE 3845 accessory mounting
- ATEX- Ex II 2 G Ex h IIC T6 Gb; Ex II 2 D Ex H IIIB T85°C Db
- SIL3 per IEC 61508:2010



## Standards- Valves

- Design: API 608
- Testing: API 598
- Threaded Connection: ASME B1.20.1 (NPT)/ ISO 228-1/ BS21
- Pressure/Temperature Rating: ASME B16.34
- Marking: MSS SP-25
- CE- PED 2014/68/UE

### Construction Features

Heavy duty rugged rack and pinion design

Anodized aluminum alloy covers with 40 micron polyester powder coating

Spring return models use multiple pre-compressed spring cartridges with polyester coating

Triple PTFE/Viton live loaded stem seal design, adjustable

316SS ball and stem, RTFE ball seats

Visual valve position indicator

Standard Namur top mounting for optional switches and positioners

Integral handwheel for manual operation

Hard anodized aluminum body, Type IP67

NPT pilot air ports and additional Namur VDI/VDE-3845 solenoid mounting pad

Full port 316 stainless steel ball valve, repairable and easily removed from pipe line

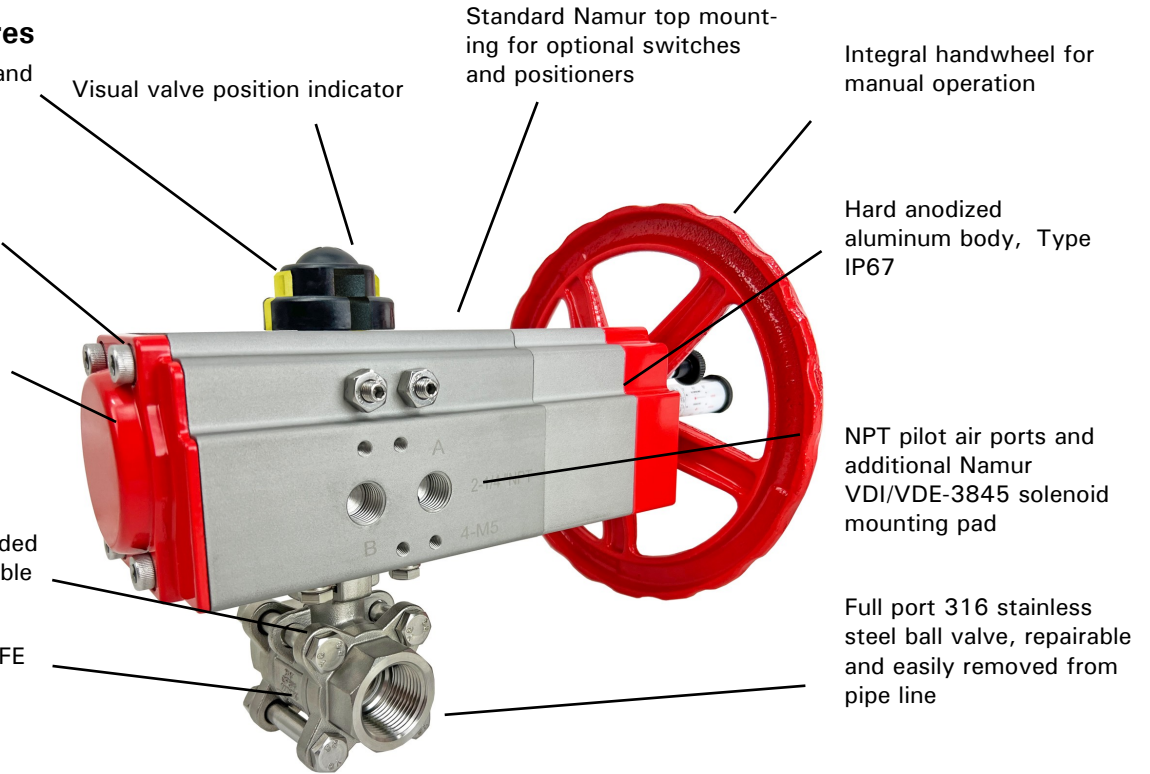

Inline mounting option below:  
A5315/A5316



International standard ISO5211 valve

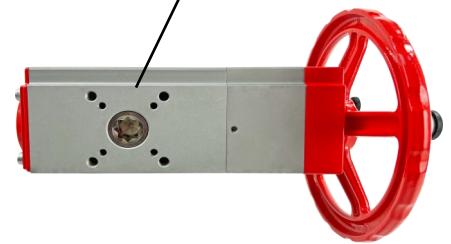

### Pressure Rating

**Valve Pressure Rating:** 1000 PSI (69 Bar) (1/4"-2")  
800 PSI (55 Bar) (2-1/2"-4") CWP non-shock,  
25 PSI saturated steam with high temp kit,  
Vacuum 29.92 InHg (2.3 x 10<sup>-3</sup> Torr)

\*See P/T chart

**Pilot Air Pressure– Double Acting:** 43-120 PSI (3-8 Bar)

**Pilot Air Pressure– Spring Return:** 87-120 PSI (6-8 Bar)

### Temperature Rating

**Ball Valve Temperature Rating:** -4 to 392° F (-20 to 200° C)

**Actuator Temperature Rating:** -4 to 176° F (-20 to 80° C)

\*See P/T chart

### Optional Accessories

- DMS: Direct Mount Solenoid
- pilot to electrically operate the ball valve
- VPS: Valve Position Switches
- limit switches to confirm valve position
- PVP: Pneumatic Valve Positioner
- position the ball with 4-20mA
- HTB: High Temperature Bracket
- increases media working temperature
- Lock out/Tag out device
- Inline mounting

## Specifications (English units)

Stock Number	Pipe Size (NPT)	Orifice Size (inch)	Cv Flow Factor	Pressure Max.(PSI)*	Air Volume/90° (cubic inches)	Cycle Time /90° (seconds)	Pilot Air Port (NPT)
<b>STAINLESS 3pc VALVE WITH PNEUMATIC/ MANUAL SPRING RETURN ACTUATOR</b>							
531602	1/4	0.5	6.9	1000	18.3	1-1	1/4
531603	3/8	0.5	6.9	1000	18.3	1-1	1/4
531604	1/2	0.6	9.7	1000	18.3	1-1	1/4
531606	3/4	0.8	18.4	1000	24.4	1-1	1/4
531608	1	1.0	55.4	1000	42.7	1-1	1/4
531610	1-1/4	1.3	89.7	1000	54.9	1-1	1/4
531612	1-1/2	1.5	144.2	1000	128.1	2-1	1/4
531616	2	2.0	226.0	1000	128.1	2-1	1/4
531620	2-1/2	2.6	289.0	800	201.4	3-1	1/4
531624	3	3.2	454.0	800	341.7	3-1	1/4
<b>STAINLESS 3pc VALVE WITH PNEUMATIC/ MANUAL DOUBLE ACTING ACTUATOR</b>							
531502	1/4	0.5	6.9	1000	18.3	1-1	1/4
531503	3/8	0.5	6.9	1000	18.3	1-1	1/4
531504	1/2	0.6	9.7	1000	18.3	1-1	1/4
531506	3/4	0.8	18.4	1000	18.3	1-1	1/4
531508	1	1.0	55.4	1000	24.4	1-1	1/4
531510	1-1/4	1.3	89.7	1000	24.4	1-1	1/4
531512	1-1/2	1.5	144.2	1000	42.7	1-1	1/4
531516	2	2.0	226.0	1000	54.9	1-1	1/4
531520	2-1/2	2.6	289.0	800	91.5	1-1	1/4
531524	3	3.2	454.0	800	128.1	1-1	1/4

Cv is the GPM of water at 60° F that will pass through the valve with 1 PSI pressure drop

\* Pressure @ 100° F (see P/T chart)

### Pressure/Temp. Chart - 1000 PSI (69 Bar)

P/T Chart (PSI/°F)				
PSI	1000	1000	100	0
°F	.4	50	330	392

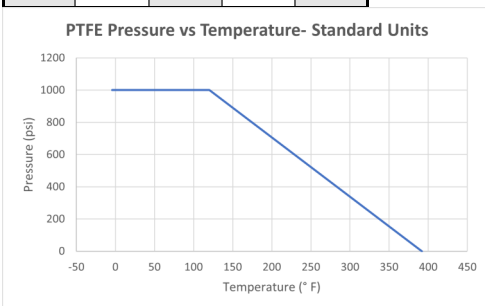

### Pressure/Temp. Chart - 800 PSI (55 Bar)

P/T Chart (PSI/°F)				
PSI	800	800	100	0
°F	.4	50	330	392

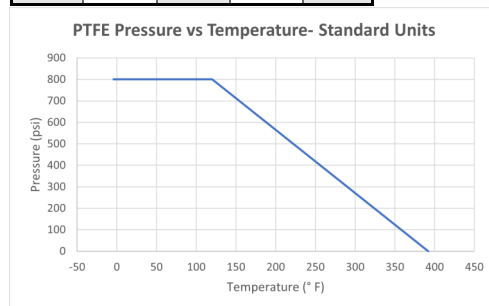

## Specifications (Metric units)

Stock Number	Pipe Size (NPT)	Orifice Size (mm)	Kv Flow Factor	Pressure Max.(Bar)*	Air Volume/90° (cubic liters)	Cycle Time/90° (seconds)	Pilot Air Port (NPT)
<b>STAINLESS 3pc VALVE WITH PNEUMATIC/ MANUAL SPRING RETURN ACTUATOR</b>							
522502C	1/4	11.5	5.9	69	0.3	1-1	1/4
522503C	3/8	12.5	5.9	69	0.3	1-1	1/4
522504C	1/2	15	8.4	69	0.3	1-1	1/4
522506C	3/4	20	15.9	69	0.4	1-1	1/4
522508E	1	25	47.9	69	0.7	1-1	1/4
522510C	1-1/4	32	77.6	69	0.9	1-1	1/4
522512C	1-1/2	38	124.7	69	2.1	2-1	1/4
522516C	2	50	195.5	69	2.1	2-1	1/4
522520C	2-1/2	65	249.7	55	3.3	3-1	1/4
522524C	3	80	392.3	55	5.6	3-1	1/4
<b>STAINLESS 3pc VALVE WITH PNEUMATIC/ MANUAL DOUBLE ACTING ACTUATOR</b>							
522402C	1/4	11.5	5.9	69	0.3	1-1	1/4
522403C	3/8	12.5	5.9	69	0.3	1-1	1/4
522404C	1/2	15	8.4	69	0.3	1-1	1/4
522406C	3/4	20	15.9	69	0.3	1-1	1/4
522408C	1	25	47.9	69	0.4	1-1	1/4
522410C	1-1/4	32	77.6	69	0.4	1-1	1/4
522412C	1-1/2	38	124.7	69	0.7	1-1	1/4
522416C	2	50	195.5	69	0.9	1-1	1/4
522420C	2-1/2	65	249.7	55	1.5	1-1	1/4
522424C	3	80	392.3	55	2.1	1-1	1/4

\* Pressure @ 70° C (see P/T chart)

### Pressure/Temp. Chart - 1000 PSI (69 Bar)

P/T Chart (BAR/°C)				
Bar	69	69	7	0
°C	-20	10	166	200

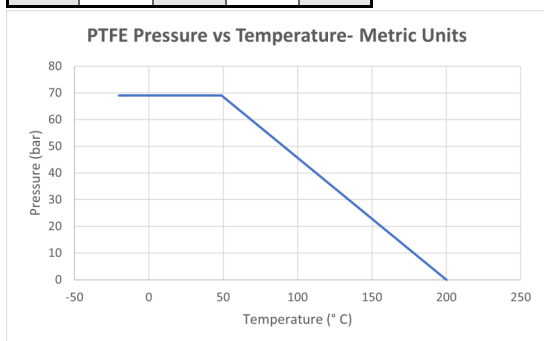

### Pressure/Temp. Chart - 800 PSI (55 Bar)

P/T Chart (BAR/°C)				
Bar	55	55	7	0
°C	-20	10	166	200

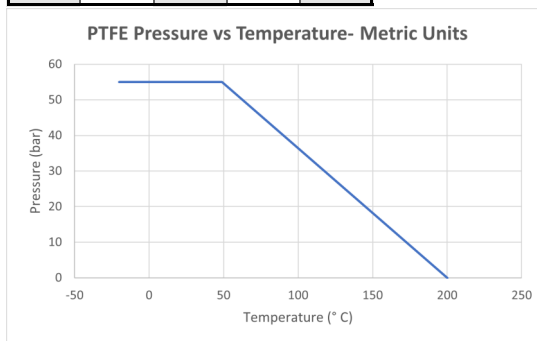

## Dimensions: Spring Return

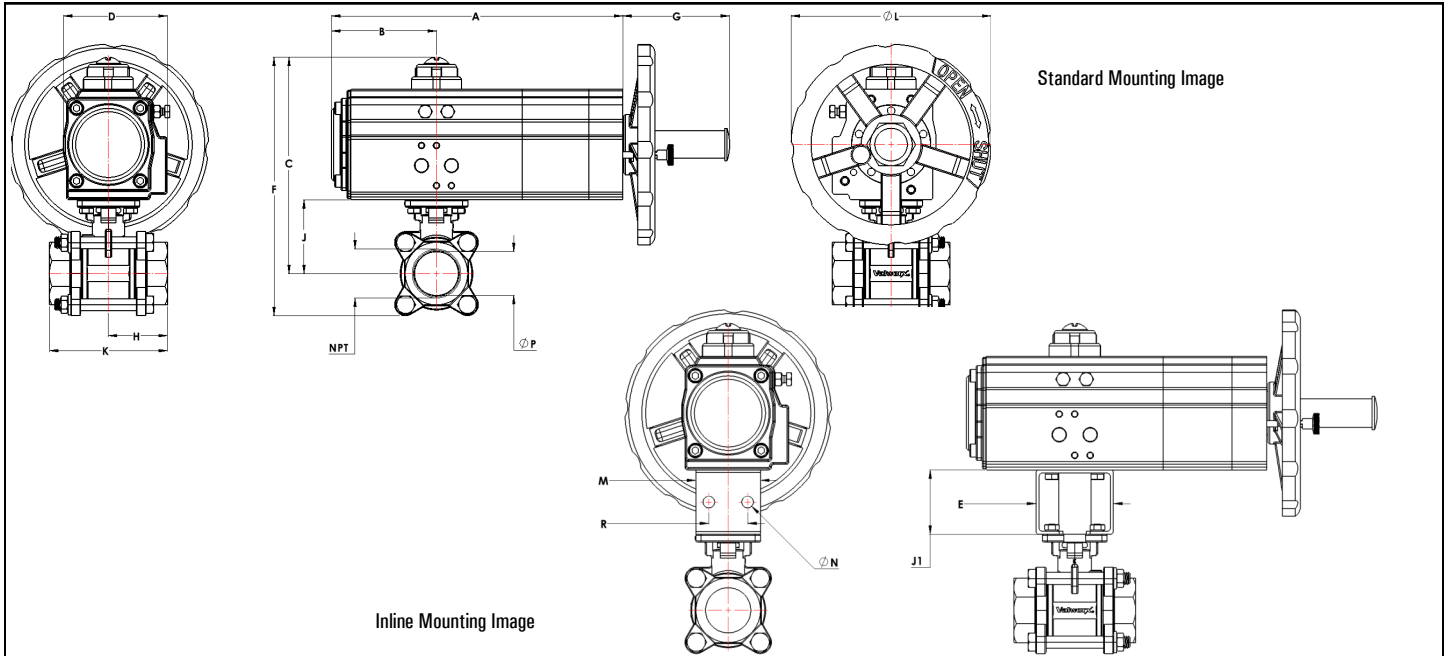

Pipe Size (NPT)		A	B	C	D	E	F	G	H	J	J1	K	L	M	N	P	R	Ports (NPT)	Weight lb / kg
1/4	inch	8.3	3.1	5.1	2.6	2.4	6.0	2.9	1.4	1.5	2.0	2.5	7.1	2.0	0.3	0.5	1.2	1/4	7.6 lb
	mm	211.0	78.7	129.5	65.0	60.0	152.4	74.0	35.0	37.0	50.0	63.5	180.0	50.0	9.0	11.5	30.0	-	3.5 kg
3/8	inch	8.3	3.1	5.1	2.6	2.4	6.0	2.9	1.3	1.5	2.0	2.5	7.1	2.0	0.3	0.5	1.2	1/4	7.6 lb
	mm	211.0	78.7	129.5	65.0	60.0	152.4	74.0	32.4	37.0	50.0	63.5	180.0	50.0	9.0	12.5	30.0	-	3.5 kg
1/2	inch	8.3	3.1	5.1	2.6	2.4	6.0	2.9	1.3	1.5	2.0	2.5	7.1	2.0	0.3	0.6	1.2	1/4	7.5 lb
	mm	211.0	78.7	129.5	65.0	60.0	152.4	74.0	32.4	37.0	50.0	63.5	180.0	50.0	9.0	15.0	30.0	-	3.4 kg
3/4	inch	9.2	3.3	6.1	2.8	2.4	6.9	3.3	1.4	1.8	2.0	2.9	7.7	2.0	0.3	0.8	1.2	1/4	11.7 lb
	mm	233.0	83.8	154.9	72.0	60.0	175.3	85.0	36.3	45.0	50.0	72.5	195.0	50.0	9.0	20.0	30.0	-	5.3 kg
1	inch	9.6	3.6	6.8	3.1	2.4	7.9	3.5	1.6	2.1	2.0	3.2	7.1	2.0	0.3	1.0	1.2	1/4	13.7 lb
	mm	244.0	91.4	172.7	80.0	60.0	200.7	89.0	40.5	53.5	50.0	81.0	180.0	50.0	9.0	25.0	30.0	-	6.2 kg
1-1/4	inch	10.7	4.2	7.4	3.6	2.4	8.7	4.0	1.9	2.3	2.0	3.7	7.7	2.0	0.3	1.3	1.2	1/4	16.8 lb
	mm	272.0	106.7	188.0	92.0	60.0	221.0	101.0	47.3	59.0	50.0	94.5	195.0	50.0	9.0	32.0	30.0	-	7.6 kb
1-1/2	inch	13.6	5.3	8.9	4.3	4.7	10.4	4.9	2.1	2.9	2.0	4.3	9.8	4.0	0.4	1.5	2.0	1/4	31.1 lb
	mm	346.0	134.6	226.1	110.0	120.0	264.2	124.0	54.0	74.8	50.0	108.0	250.0	102.0	11.0	38.0	50.0	-	14.1 kg
2	inch	13.6	5.3	9.3	4.3	4.7	11.1	4.9	2.4	3.3	2.0	4.8	9.8	4.0	0.4	2.0	2.0	1/4	33.6 lb
	mm	346.0	134.6	236.2	110.0	120.0	281.9	124.0	60.8	83.5	50.0	121.5	250.0	102.0	11.0	50.0	50.0	-	15.3 lb
2-1/2	inch	15.8	5.9	11.2	5.0	4.7	13.4	5.2	3.1	4.3	2.0	6.2	15.7	4.0	0.4	2.7	2.0	1/4	60.4 lb
	mm	402.0	149.9	284.5	128.0	120.0	340.4	133.0	78.8	108.8	50.0	157.5	400.0	102.0	11.0	65.0	50.0	-	27.9 kg
3	inch	20.1	7.8	12.5	5.4	4.7	15.1	6.3	3.7	4.7	2.0	7.5	19.7	4.0	0.4	3.2	2.0	1/4	88.7 lb
	mm	511.0	198.1	317.5	138.0	120.0	383.5	161.0	95.0	118.3	50.0	190.0	500.0	102.0	11.0	80.0	50.0	-	40.3 kg

## Dimensions: Double Acting

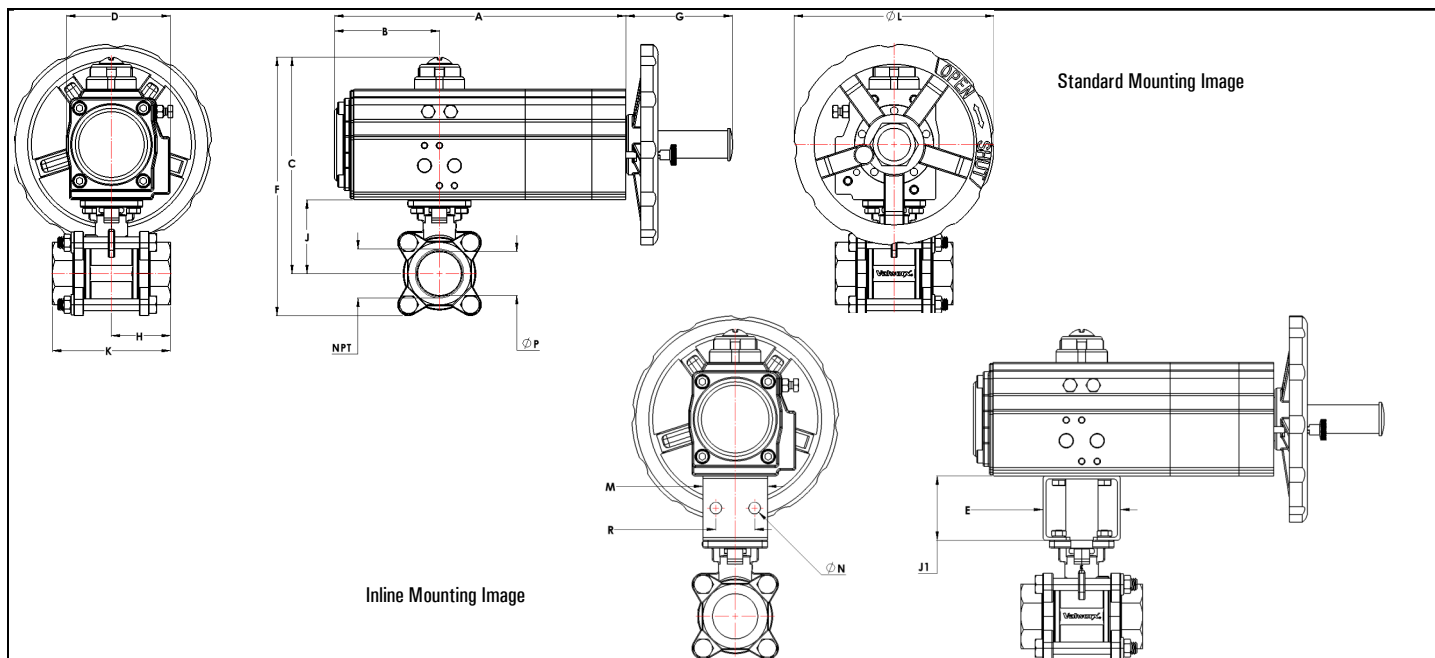

Pipe Size (NPT)		A	B	C	D	E	F	G	H	J	J1	K	L	M	N	P	R	Ports (NPT)	Weight lb / kg
1/4	inch	8.3	3.1	5.1	2.6	2.4	6.0	2.9	1.4	1.5	2.0	2.5	7.1	2.0	0.3	0.5	1.2	1/4	7.6 lb
	mm	211.0	78.8	129.5	65.0	60.0	152.4	74.0	35.0	37.0	50.0	63.5	180.0	50.0	9.0	11.5	30.0	-	3.5 kg
3/8	inch	8.3	3.1	5.1	2.6	2.4	6.0	2.9	1.3	1.5	2.0	2.5	7.1	2.0	0.3	0.5	1.2	1/4	7.6 lb
	mm	211.0	78.7	129.5	65.0	60.0	152.4	74.0	32.4	37.0	50.0	63.5	180.0	50.0	9.0	12.5	30.0	-	3.5 kg
1/2	inch	8.3	3.1	5.1	2.6	2.4	6.0	2.9	1.3	1.5	2.0	2.5	7.1	2.0	0.3	0.6	1.2	1/4	7.5 lb
	mm	211.0	78.7	129.5	65.0	60.0	152.4	74.0	32.4	37.0	50.0	63.5	180.0	50.0	9.0	15.0	30.0	-	3.4 kg
3/4	inch	8.3	3.1	5.4	2.6	2.4	6.2	2.9	1.4	1.8	2.0	2.9	7.1	2.0	0.3	0.8	1.2	1/4	7.7 lb
	mm	211.0	78.7	137.2	65.0	60.0	157.5	74.0	36.3	45.0	50.0	72.5	180.0	50.0	9.0	20.0	30.0	-	3.5 lb
1	inch	9.2	3.3	6.4	2.8	2.4	7.5	3.3	1.6	2.1	2.0	3.2	7.7	2.0	0.3	1.0	1.2	1/4	11.8 lb
	mm	233.0	83.8	162.6	72.0	60.0	190.5	85.0	40.5	53.5	50.0	81.0	195.0	50.0	9.0	25.0	30.0	-	5.4 kg
1-1/4	inch	9.2	3.3	6.6	2.8	2.4	7.9	3.3	1.9	2.3	2.0	3.7	7.7	2.0	0.3	1.3	1.2	1/4	12.7 lb
	mm	233.0	83.8	167.6	72.0	60.0	200.7	85.0	47.3	59.0	50.0	94.5	195.0	50.0	9.0	32.0	30.0	-	5.8 kg
1-1/2	inch	9.6	3.6	7.6	3.1	3.1	9.1	3.5	2.1	2.9	2.0	4.3	7.1	2.8	0.3	1.5	1.4	1/4	15.8 lb
	mm	244.0	91.4	193.0	80.0	80.0	231.1	89.0	54.0	74.8	50.0	108.0	180.0	70.0	9.0	38.0	35.0	-	7.2 kg
2	inch	10.7	4.2	8.4	3.6	3.1	10.2	4.0	2.4	3.3	2.0	4.8	7.7	2.8	0.3	2.0	1.4	1/4	20.5 lb
	mm	272.0	106.7	213.4	92.0	80.0	259.1	101.0	60.8	83.5	50.0	121.5	195.0	70.0	9.0	50.0	35.0	-	9.1 kg
2-1/2	inch	13.4	5.2	9.7	3.9	3.1	11.9	4.3	3.1	4.3	2.0	6.2	9.8	2.8	0.3	2.7	1.4	1/4	36.4 lb
	mm	341.0	132.1	246.4	98.0	80.0	302.3	109.0	78.8	108.8	50.0	157.5	250.0	70.0	9.0	65.0	35.0	-	16.5 kg
3	inch	13.6	5.3	10.7	4.3	4.7	13.3	4.9	3.7	4.7	2.0	7.5	9.8	4.0	0.4	3.2	2.0	1/4	47.6 lb
	mm	346.0	134.6	271.8	110.0	120.0	337.8	124.0	95.0	118.3	50.0	190.0	250.0	102.0	11.0	80.0	50.0	-	21.6 kg