

READ THESE INSTRUCTIONS CAREFULLY BEFORE INSTALLING OR CONNECTING POWER TO THE ACTUATOR. THE ACTUATOR MUST BE INSTALLED, COMMISSIONED, OPERATED AND REPAIRED BY QUALIFIED PERSONNEL. COMPLY WITH ALL APPLICABLE CODES, STANDARDS AND SAFETY REGULATIONS.

STORAGE

Actuators should be stored in a clean, dry environment at all times.

INTRODUCTION

This document provides installation, operation and maintenance instructions for Valworx 5617 series electric on-off actuators. These actuators are typically used to operate quarter-turn valves. Every actuator has been fully tested prior to shipment to ensure trouble free operation.

MOUNTING

The actuator can be mounted in any orientation. Allow enough room around actuator for manual operation as well as any maintenance. Valves can be direct mounted to the actuator using standard ISO5211 international mounting pad.



TEMPERATURE RATING

Operating temperature range of the actuator is -22 to +140°F (-30 to +60°C). Heat from the working medium (fluid) should not allow actuator to exceed these temperature limits. Optional high temperature valve mounting kits are available to increase the allowable media (fluid) working temperature.

ENCLOSURE RATING

The rugged aluminum housing is rated Type 4X and IP67 weatherproof. These general purpose actuators should not be used in explosion proof or hazardous applications.

VISUAL POSITION INDICATOR

Actuators are supplied with a local visual valve position indicator. This indicator is yellow and located on top of the actuator. Indicator will show the open and closed (on-off) position of the quarter-turn actuator (valve).

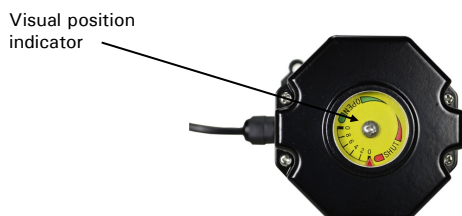

DUTY CYCLE AND MOTOR PROTECTION

The rugged 5617 series actuators are rated 60% duty cycle. Actuators are equipped with thermal overload protection with automatic reset to help protect the motor.

POSITION CONFIRMATION SWITCHES

On-Off actuators include two auxiliary limit switches used to confirm the actuator (valve) open and closed positions (use of these switches is optional). These switches are preset at the factory and do not need adjusting under normal conditions.

MANUAL OVERRIDE

Valworx 5617 series electric actuators have a manual override for use during setup or loss of electrical power. To operate the manual override, first "REMOVE ALL ELECTRICAL POWER TO THE ACTUATOR" then open the manual override protective cover located on the side of the actuator. Insert a hex wrench (provided) and rotate open (clockwise) or close as required. Do not exert excessive force at end of stroke, this may damage the actuator.



WARNING: Disconnect electrical power prior to operating manual override, removing covers or service.

MAINTENANCE

There are no internal parts that require regular maintenance. The gear drive is pre-lubricated for life. The housing may be cleaned with warm soapy water (no solvents). The actuator should be cycled at least once per month. **DO NOT PRESSURE WASH.**

ELECTRICAL WIRING

Confirm the actuator VOLTAGE is correct, then connect wiring to cable according to appropriate wiring diagram.

For convenience, wiring diagrams for each actuator are attached to the side of each actuator.

User/installer to supply a motor control relay, 3-way switch or other suitable switching device to control the actuator position. Actuator should have its own fused and isolated circuit. Do not connect actuators in parallel.

PREWIRED CABLE

For ease of installation, the actuator is supplied with 3 meters (9.8 feet) of prewired cable. The outside diameter of the supplied cable is 9mm. Cable type: UL style 2464, jacketed, 18 AWG, 7 conductor



Before connecting power, confirm correct VOLTAGE is being applied. Incorrect voltage may damage actuator and void the warranty.

OPERATION

Standard on-off (open-closed) electric actuator uses power-to-open and power-to-close, stays in the last known position with loss of power. On receipt of a continuous voltage signal, the motor runs and via a rugged gear system rotates the actuator output (valve) 90 degrees. The motor is automatically stopped by internal cams striking limit switches. On receipt of a reversing continuous signal, the motor turns in the opposite direction reversing the actuator position. The output drive rotates counter-clockwise (viewed from the top of actuator) when moving to the on or open position.



Prewired electrical cable with flying leads

AC Voltage Wiring Diagram

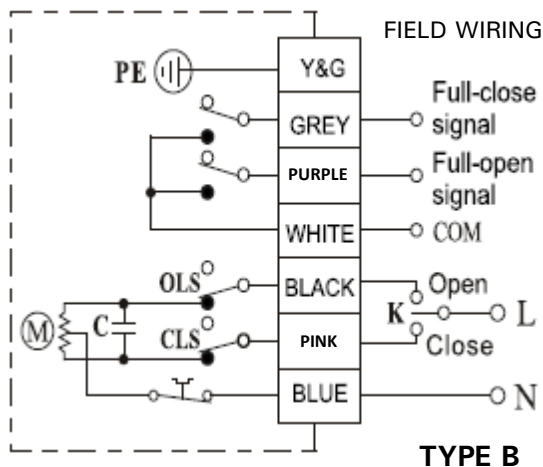

TYPE B

FOR SUPPLY CONNECTIONS, USE WIRES SUITABLE FOR AT LEAST 75°C (167°F) Employer Des Fils D'alimentation Qui Conviennent Pour Au Moins 75°C

TO BE CONNECTED TO A CLASS 2 CIRCUIT ONLY
Raccorder Uniquement a un circuit de classe 2

DC Voltage Wiring Diagram

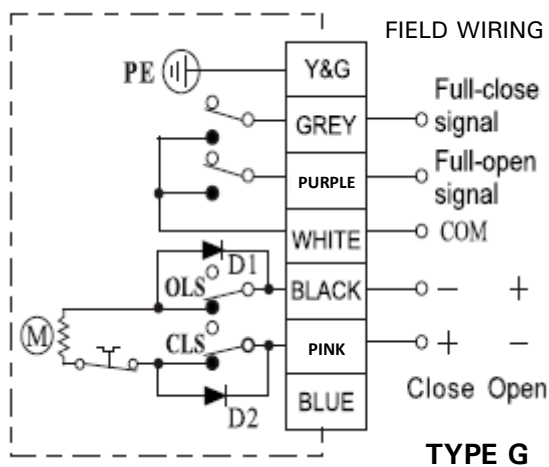

TYPE G

FOR SUPPLY CONNECTIONS, USE WIRES SUITABLE FOR AT LEAST 75°C (167°F) Employer Des Fils D'alimentation Qui Conviennent Pour Au Moins 75°C

TO BE CONNECTED TO A CLASS 2 CIRCUIT ONLY
Raccorder Uniquement a un circuit de classe 2

AC Voltage Wiring:

BLUE: Power Neutral (N)

User/Installer to Supply Relay or 3-way Switch (K):

PINK: Power (L) to Red - Actuator OFF or CLOSED

BLACK: Power (L) to Black - Actuator ON or OPEN

Auxiliary Position Confirmation Limit Switches

WHITE: Common

PURPLE: Open status confirmation signal

GREY: Closed status confirmation signal

Ground

YELLOW/GREEN: Earth ground (PE)

DC Voltage Wiring:

User/Installer to Supply Reversing Relay or Switch

DC Power to PINK (+) and BLACK (-) - Actuator OFF or CLOSED

DC Power to BLACK (+) and PINK (-) - Actuator ON or OPEN

Auxiliary Position Confirmation Limit Switches

WHITE: Common

PURPLE: Open status confirmation signal

GREY: Closed status confirmation signal

Ground

YELLOW/GREEN: Earth ground (PE)

For DC powered actuators use a dedicated regulated power supply sized 3 times motor F.L. amp rating.

NOTE: Auxiliary dry contact limit switches are rated 3A@125/250VAC, 30VDC resistive load rating.