

READ THESE INSTRUCTIONS CAREFULLY BEFORE INSTALLING OR CONNECTING POWER TO THE ACTUATOR. THE ACTUATOR MUST BE INSTALLED, COMMISSIONED, OPERATED AND REPAIRED BY QUALIFIED PERSONNEL. COMPLY WITH ALL APPLICABLE CODES, STANDARDS AND SAFETY REGULATIONS.

STORAGE

Actuators should be stored in a clean, dry environment at all times.

INTRODUCTION

This document provides installation, operation and maintenance instructions for Valworx 5617 series electric actuators with EPS positioner. These actuators are typically used to operate quarter-turn valves. Every actuator has been fully tested prior to shipment to ensure trouble free operation.

MOUNTING

The actuator can be mounted in any orientation. Allow enough room around actuator for manual operation as well as any maintenance. Valves can be direct mounted to the actuator using standard ISO5211 international mounting pad.



TEMPERATURE RATING

Operating temperature range of the actuator is -13 to +131°F (-25 to +55°C). Heat from the working medium (fluid) should not allow actuator to exceed these temperature limits. Optional high temperature valve mounting kits are available to increase the allowable media (fluid) working temperature.

ENCLOSURE RATING

The rugged aluminum housing is rated Type 4X and IP67 weatherproof. These general purpose actuators should not be used in explosion proof or hazardous applications.

VISUAL POSITION INDICATOR

Actuators are supplied with a local visual valve position indicator. This indicator is yellow and located on top of the actuator. Indicator will show the open and closed (on-off) position of the quarter-turn actuator (valve).

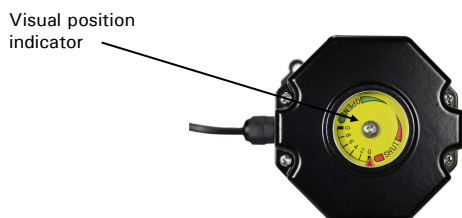

DUTY CYCLE AND MOTOR PROTECTION

The rugged 5617 series actuators are rated 60% duty cycle. Actuators are equipped with thermal overload protection with automatic reset to help protect the motor.

POSITION CONFIRMATION

EPS actuators include a position output monitoring signal used to confirm the actuator (and valve) position during modulation.

MANUAL OVERRIDE

Valworx 5617 series electric actuators have a manual override for use during setup or loss of electrical power. To operate the manual override, first "REMOVE ALL ELECTRICAL POWER TO THE ACTUATOR" then open the manual override protective cover located on the side of the actuator. Insert a hex wrench (provided) and rotate open (clockwise) or close as required. Do not exert excessive force at end of stroke, this may damage the actuator.



WARNING: Disconnect electrical power prior to operating manual override, removing covers or service.

MAINTENANCE

There are no internal parts that require regular maintenance. The gear drive is pre-lubricated for life. The housing may be cleaned with warm soapy water (no solvents). The actuator should be cycled at least once per month. **DO NOT PRESSURE WASH.**

ELECTRICAL WIRING

Confirm the actuator VOLTAGE is correct, then connect wiring to provided cable according to appropriate wiring diagram.

Wiring diagrams for each actuator are attached to the side of the actuator enclosure.

Actuator will accept a standard 4-20mA analog input control signal. Actuator should have its own fused and isolated circuit. Do not connect actuators in parallel.

PREWIRED CABLE

For ease of installation, the actuator is supplied with 3 meters (9.8 feet) of prewired cable. The outside diameter of the supplied cable is 9mm. Cable type: UL style 2464, jacketed, 18 AWG, 7 conductor

 Before connecting power, confirm correct VOLTAGE is being applied. Incorrect voltage may damage the actuator.

 **WARNING:** Never connect the main power supply to the input signal or output signal wires. This will damage the actuator beyond repair and is not covered by warranty.

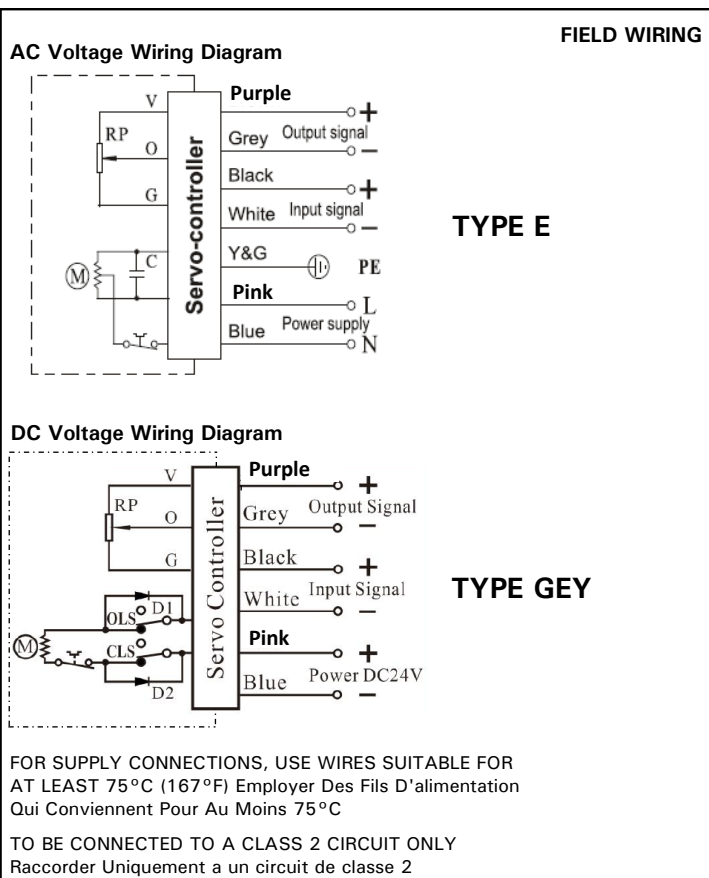

Field Wiring:

BLUE: Power Supply - Neutral (N) or Negative (-)

PINK: Power Supply - Line (L) or Positive (+)

WHITE: 4-20mA Input Signal (-)

BLACK: 4-20mA Input Signal (+)

GREY: 4-20mA Output Monitoring Signal (-)

PURPLE: 4-20mA Output Monitoring Signal (+)

YELLOW/GREEN: Earth ground (PE)

OPERATION

Valworx 5617 series electric actuators with EPS- Electronic Positioning System provide an accurate valve positioning function whereby the movement of the actuator is controlled by a 4-20mA analog input control signal. Any change in the control input signal results in a corresponding and proportional change in the position of the actuator drive output anywhere between 0-90°. An internal microprocessor on the EPS circuit board continuously monitors the analog input and output signals and compares them to the physical position via a precision potentiometer feedback system, moving the drive output as required to balance the signals.



Prewired electrical cable with flying leads

LED LIGHTS AND DIP SWITCHES

Lights and dip switches are located under the black top cover of the 5617 series actuators.

LED L1: Green indicator LED L1 lights up when power is applied to the actuator during normal operation.

LED L2: RED indicator LED L2 lights up when there is a fault condition during normal operation. The most common fault condition is the input signal wire is open, shorted or exceeds normal range. The actuator will move to the preset failure mode (open, closed or stop in place) as long as main power is maintained.

SETUP AND CALIBRATION

ALL ACTUATORS ARE CALIBRATED AND TESTED AT THE FACTORY PRIOR TO SHIPMENT. NO ADJUSTMENTS ARE REQUIRED FOR MOST APPLICATIONS. If recalibration is required, contact Valworx for a copy of the setup and calibration instructions.

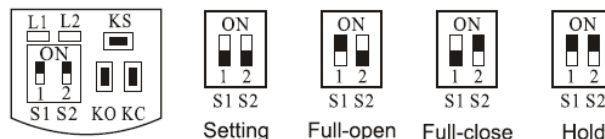

Dip Switch Setup and Manual Push Button Control			S1	S2
4-20mA Input	Auto Mode S (default setting)	Actuator closed with 4mA signal, open with 20mA signal. Stops with loss of control signal	ON	ON
	Auto Mode C	Actuator closed with 4mA signal, open with 20mA signal. Moves to closed position with loss of control signal	OFF	ON
	Auto Mode O	Actuator closed with 4mA signal, open with 20mA signal. Moves to open position with loss of control signal	ON	OFF
Electrical Manual Operation	Manual Mode - Open	Set S1 and S2 to off and manually move the actuator to open position using push button KC	OFF	OFF
	Manual Mode - Closed	Set S1 and S2 to off and manually move the actuator to closed position using push button KO	OFF	OFF