

READ THESE INSTRUCTIONS CAREFULLY BEFORE INSTALLING. DAMAGE CAUSED BY NON COMPLIANCE WILL NOT BE COVERED BY WARRANTY.

INTRODUCTION

This document provides installation, operation and maintenance instructions for Valworx 5497 series check valves.

MEDIA

Media should be non-particulate and free-flowing. Highly viscous fluids and media containing solids are generally not suitable for axial check valves.

PRESSURE RATING

The 5497 series check valves have a maximum pressure rating of 232 PSI (1/2"-4") at 73° F. Refer to the datasheet for minimum back pressure.

TEMPERATURE RATING

Valve temperature rating is 15 to 230°F (-9 to 110°C).

INSTALLATION

Ensure the valve is clean and in good operating condition prior to installation.

Check valves work best when the fluid flow is laminar. To ensure this, the valve should be installed with a straight pipe run of 5 x Nominal Pipe Diameter (NPD) upstream and 10 x NPD downstream. The valve may be installed close to the inlet of an isolation valve provided the isolating valve is full port and normally open.

Figure 1: Pipe Installation

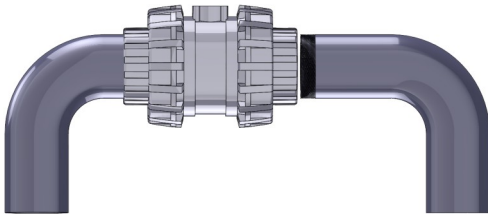

When the recommended pipe run is not possible flow straighteners should be used. Close installation to pumps or other equipment that introduces turbulence can cause chattering of the ball against the valve body, increasing wear and reducing valve performance and service life.

Figure 2: Pump Installation

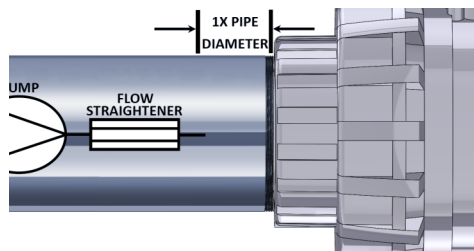

A minimum backpressure of 3 PSI is required to re-seat the ball.

ORIENTATION & SIZING

The valve may be installed in either a horizontal or vertical orientation. Horizontal installation is preferred as it eliminates gravity and static head considerations. However, concentric check valves are non-draining and should be installed in horizontal applications only where self-draining is not required.

When sizing the check valve in a vertical orientation with downward flow, the head pressure of the column of fluid above the valve must be taken into account.

Note that the fluid path through the valve causes significant pressure loss which must be accounted for when determining pipe size. The check valve Cv should be slightly *lower* than the desired nominal Cv.



OPERATION

The check valve allows unidirectional flow when upstream pressure unseats a captive ball, allowing media to flow around the ball. When upstream pressure is shut off, back pressure re-seats the ball, preventing backflow.

PVC ball check valves operate passively and therefore do not require any external energy source.

Figure 3: Valve Open

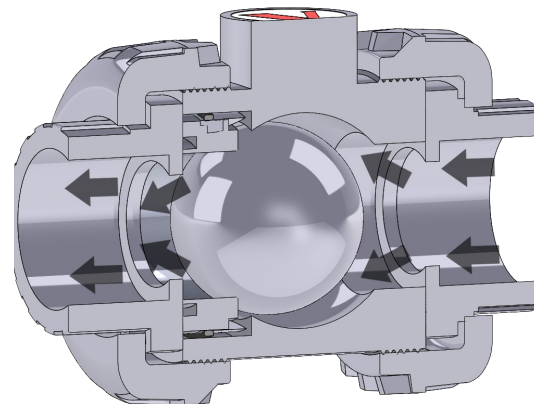

Figure 4: Valve Closed

